

Orion SkyView™ Pro GoTo System

#7817



 **ORION**
TELESCOPES & BINOCULARS

Providing Exceptional Consumer Optical Products Since 1975

Customer Support:
www.OrionTelescopes.com/contactus

Corporate Offices:
89 Hangar Way, Watsonville CA 95076 - USA

Copyright © 2014 Orion Telescopes & Binoculars

All Rights Reserved. No part of this product instruction or any of its contents may be reproduced, copied, modified or adapted, without the prior written consent of Orion Telescopes & Binoculars.



Figure 1. The SkyView Pro GoTo System (not all parts on parts list are shown)

Congratulations on your purchase of the Orion SkyView Pro GoTo system. The GoTo system will add brains to your SkyView Pro equatorial mount's brawn. Once the GoTo system has been installed, it enables you to locate and automatically slew to thousands of celestial objects using the included hand controller. Views of the planets, Moon, galaxies, nebulae, stars, and star clusters will all be as close as the touch of a button. You'll find using your SkyView Pro GoTo mount will provide an entirely new astronomical experience that will open up new realms of celestial exploration.

These instructions will help you install and properly use the SkyView Pro GoTo system. Please read them over thoroughly before getting started. It may take a few observing sessions to become familiar with all the features of the SkyView Pro GoTo system, so keep this manual handy as you master your mount's operation.

1. Parts List

Qty.	Description
1	Declination (Dec.) GoTo motor assembly
1	Right ascension (R.A.) GoTo motor assembly
2	Brass gears w/ 2mm socket-head set screws
1	Motor control box
1	Motor control box bracket
1	GoTo hand controller
1	GoTo hand controller cable (coiled, 30")
1	GoTo hand controller bracket
1	Motor Cable (13"): motor control box-to-R.A. motor
1	Motor Cable (27"): R.A. motor-to-Dec. motor
1	Hand controller-to-PC cable (5')
1	12V DC power cable
1	Declination (Dec.) motor cover
1	Right ascension (R.A.) motor cover
1	Right ascension (R.A.) motor attachment screw (40mm length)
1	Declination (Dec.) motor attachment screw (17mm length)
1	Phillips screw (10mm length)
2	Phillips screws (8mm length)
2	flat washers, 10mm outer diameter
1	lock washer, 9mm outer diameter
1	4mm hex key
1	2mm hex key
1	Phillips screwdriver

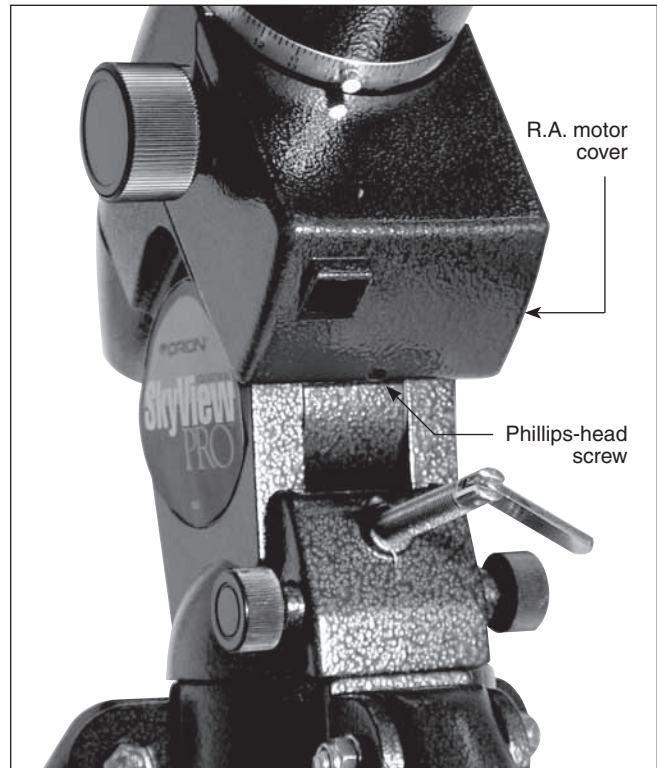

Figure 2. The R.A. motor cover

2. Installation

Attaching the R.A. GoTo Motor

Remove the telescope tube, counterweight, and counterweight shaft from the SkyView Pro mount before attaching the motor drives.

1. Remove the R.A. motor cover from the mount by loosening the Phillips head screw on the bottom of the cover (**Figure 2**). Slide the cover off the mount.
2. Remove the R.A. slow-motion control knob from the R.A. worm gear shaft. The slow-motion knob will not be usable once the SkyView Pro GoTo system has been installed. All slow-motion adjustments will be made using the GoTo hand controller.

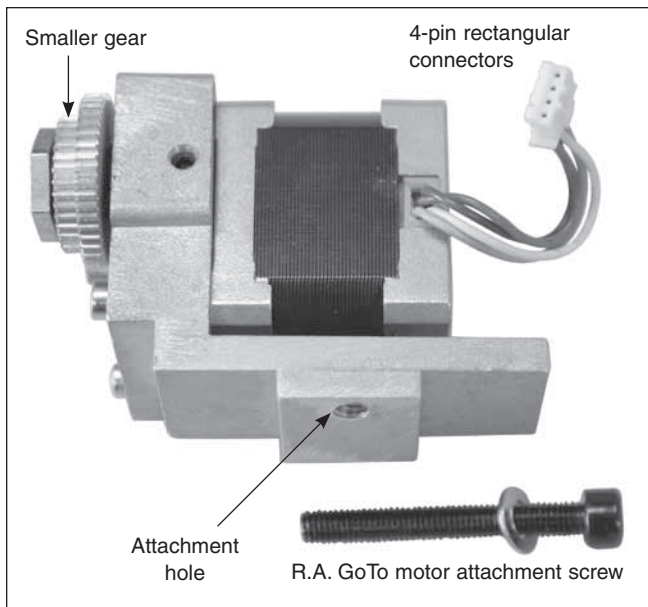

Figure 3. The R.A. GoTo motor assembly

3. The R.A. GoTo motor assembly is identified by the 4-pin rectangular connector attached to the motor body (**Figure 3**). The motor will be attached to the mount by a 40mm long socket-head cap screw that goes through the hole in the rear of the equatorial mount, just above the rear latitude adjustment L-bolt (**Figure 4**). It will be helpful to remove the rear latitude adjustment L-bolt while installing the R.A. GoTo motor. Place one of the 10mm flat washers onto the R.A. motor attachment screw. Attach the R.A. motor attachment screw to the end of a 4mm hex key and push it up through the hole in the rear of the equatorial mount (**Figure 4**). Hold the R.A. GoTo drive in your hand so its threaded hole meets the screw as it comes out the other end of the hole. Thread the screw into the threaded hole of the R.A. motor assembly until secure, but do not overtighten. You will need to make small adjustments to the motor position in the following steps.

4. Slide the geared end of one of the small brass gears onto the worm gear shaft so it resembles **Figure 5**. Rotate the small brass gear so that one of the setscrews will press against the flat part of the R.A. worm gear shaft. Secure the small brass gear by tightening the setscrews with the included 2mm hex key, but do not overtighten. You may have to make small adjustments to the gear's position in the following step to ensure proper gear engagement.

5. Make certain that the teeth of the **smaller** motor assembly gear correctly mesh with the teeth of the brass gear (**Figure 6**). Also, make certain the gears are not too tightly pressed together. You may have to adjust the way the gears mesh by tightening or loosening the socket-head cap screw that is used to attach the R.A. GoTo motor assembly to the mount and/or the small setscrews on the brass gear. If the gears are not meshed correctly or are too tightly pressed together, then the drive will not track properly, or at all. This attachment process is tricky, and it may take several adjustments before the gears properly mesh.

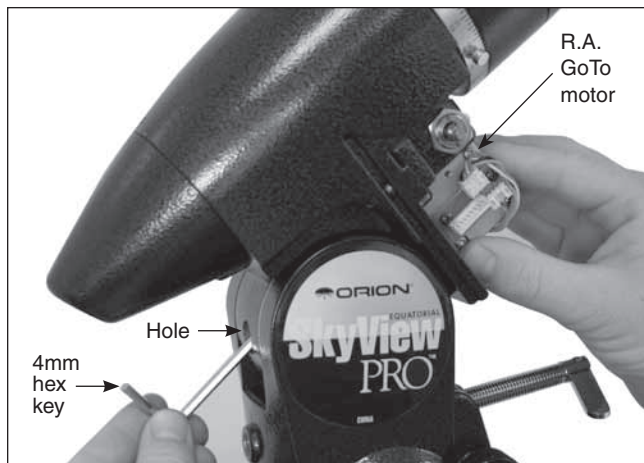

Figure 4. Attaching the R.A. GoTo motor

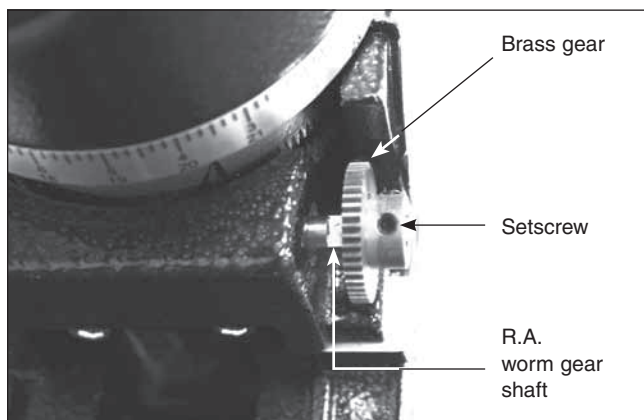

Figure 5. Correct orientation of brass gear for R.A. axis

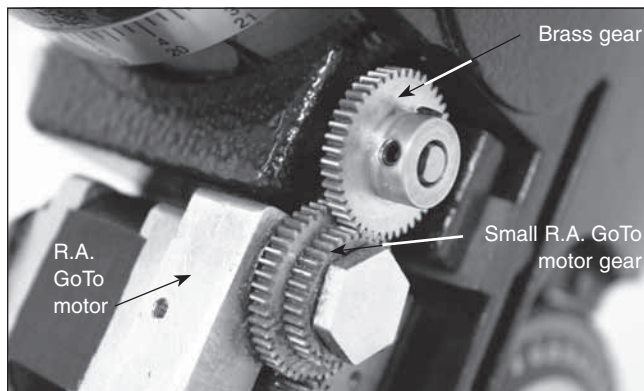

Figure 6. Correctly meshed gears (R.A.)

6. Take the R.A. GoTo motor cover and hold it near the installed R.A. GoTo motor. On the inside of the motor cover, you will see a set of wires with a white 4-pin rectangular connector attached. Carefully connect the 4-pin rectangular connector attached to the R.A. GoTo motor cover to the corresponding 4-pin rectangular connector on the R.A. GoTo motor. Once connected, the wiring of your R.A. GoTo motor should resemble **Figure 7**.

Note: Inside the R.A. GoTo motor cover you will find an additional set of wires connected to each other with 5-pin rect-

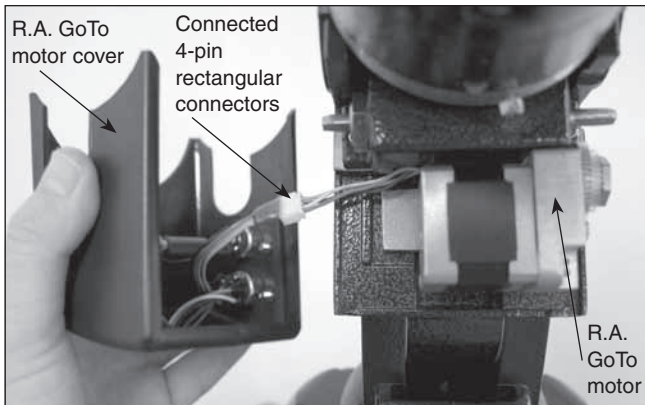

Figure 7. R.A. GoTo motor wiring

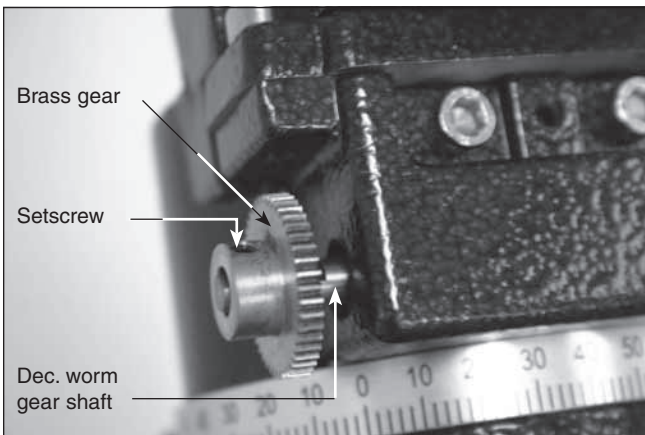

Figure 8. Correct orientation of brass gear for Dec. axis

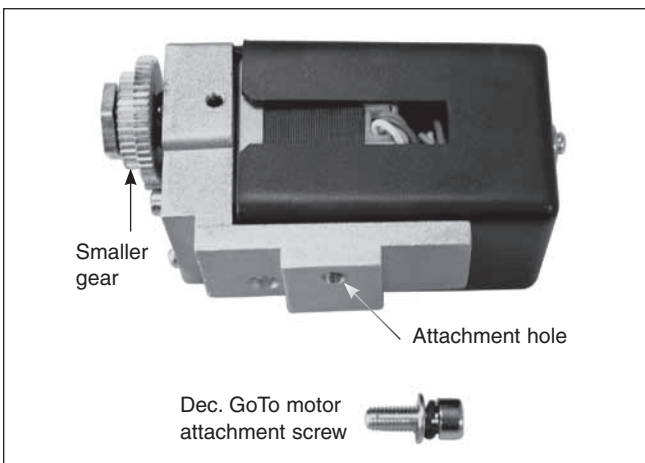

Figure 9. The Dec. GoTo motor assembly

angular connectors. Make certain these wires are connected before proceeding to step 7.

- Once the rectangular connector has been attached, you can install and secure the R.A. GoTo motor cover with the 10mm long Phillips head screw. Don't forget to re-install the rear latitude adjustment L-bolt if you have removed it previously.

Note: There is a small packet of grease included with your SkyView Pro GoTo system. Once you have installed the GoTo

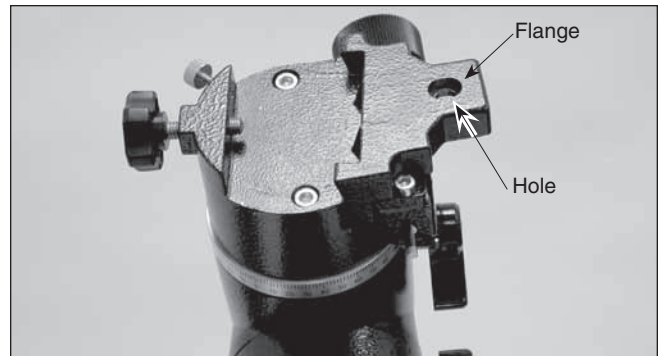

Figure 10. The location of the flange on the mount

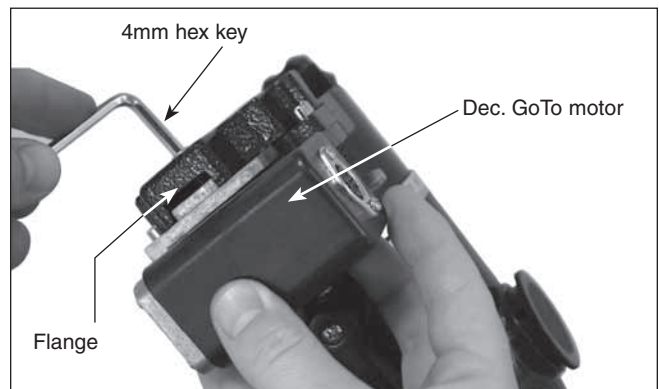

Figure 11. Attaching the Dec. GoTo motor

motor so the gears mesh properly, you can apply a very small amount of the included grease to the meshed gears to ensure optimal gear mating.

Attaching the Dec. GoTo Motor

Before attaching the Dec. GoTo motor drive, the telescope tube must be removed from the equatorial mount.

- Remove the Dec. slow-motion control knob from the Dec. worm gear shaft. The Slow-motion knob will not be usable once the SkyView Pro GoTo system has been installed. All slow-motion adjustments will be made using the GoTo hand controller.
- Slide the geared end of the remaining small brass gear onto the Dec. worm gear shaft of your SkyView Pro mount so it resembles **Figure 8**. Rotate the small brass gear so that one of the setscrews will press against the flat part of the Dec. worm gear shaft. Secure the small brass gear by tightening the setscrews with the included 2mm hex key, but do not overtighten. You may have to make small adjustments to the gear's position in the following step to ensure proper gear engagement.
- The Dec. GoTo motor assembly is identified by its black, rectangular body (**Figure 9**). It is attached to the equatorial mount using the Dec. GoTo motor attachment screw that goes through the hole in the flange at the top of the equatorial mount (**Figure 10**). The motor assembly should be attached so that it is oriented as shown in **Figure 11**. Hold the motor assembly so that its threaded hole lines up with the hole in the top of the mount. Place the lock washer and

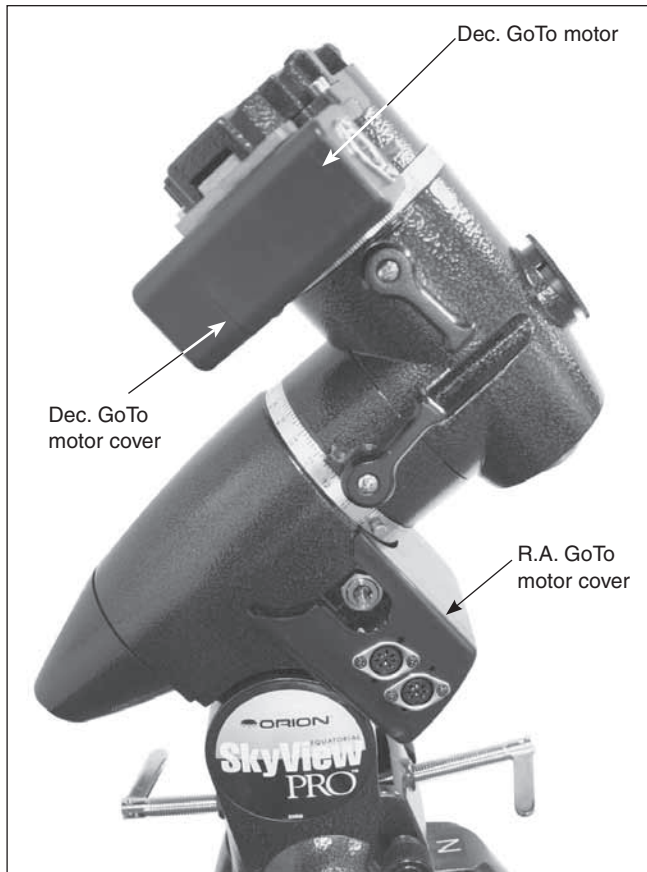

Figure 12. Installed GoTo motors

then a flat washer onto the Dec. GoTo motor attachment screw. Use the 4mm hex key to thread the attachment screw into the motor assembly attachment hole until it is secure, but do not overtighten.

4. Make certain that the teeth of the **smaller** gear of the Dec. GoTo motor assembly meshes with the brass gear. Also, make certain the gears are not too tightly pressed together. You can adjust the way the gears mesh by tightening or loosening the socket-head cap screw that is used to attach the Dec. GoTo motor assembly to the mount and/or the small setscrews on the brass gear. If the gears are not meshed correctly or are too tightly pressed together, then the drive will not track properly, or at all. This attachment process is tricky, and it may take several adjustments before the gears properly mesh.

Note: There is a small packet of grease included with your SkyView Pro GoTo system. Once you have installed the GoTo motor so the gears mesh properly, you can apply a very small amount of the included grease to the meshed gears to ensure optimal gear mating.

5. Once the Dec. GoTo motor and gear have been installed and the gears mesh appropriately, you can install and secure the Dec. GoTo motor cover with the two 8mm long Phillips screws. Once you have installed the Dec. GoTo motor and cover, your mount should resemble **Figure 12**.

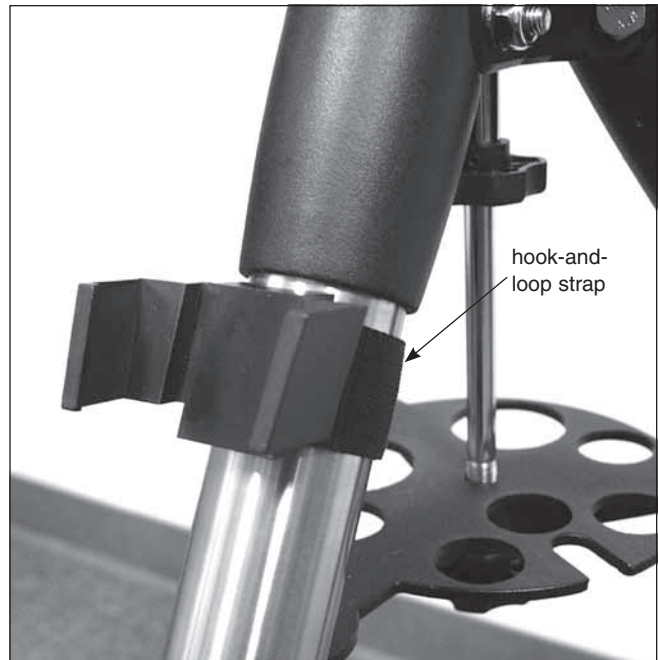

Figure 13. Installing the GoTo hand controller bracket

Attaching the Motor Control Box

Once both of the GoTo motors have been installed, you can attach and connect the motor control box.

1. Attach the motor control box bracket to the top of one of the legs of the SkyView Pro tripod. It will be most convenient to attach the bracket to the leg closest to the side of the R.A. GoTo motor cover with the two 8-pin circular jacks.
2. Slide the motor control box into the motor control box bracket.
3. Connect one end of the 13" long motor cable to the 8-pin circular jack marked "R.A. IN" on the R.A. GoTo motor cover.
4. Connect the other end of the 13" long motor cable to the 8-pin circular jack on the motor control box.
5. Connect one end of the 27" long motor cable to the 8-pin circular jack marked "Dec. OUT" on the R.A. GoTo motor cover.
6. Connect the other end of the 27" long motor cable to the 8-pin circular jack on the Dec. GoTo motor.

Attaching the GoTo Hand Controller

1. Strap the included hand controller bracket to a tripod leg above the tripod center support tray using the hook-and-loop strap, as shown in **Figure 13**.
2. The SkyView Pro GoTo hand controller cable is a 30" long coiled cable with modular connectors (RJ-45) on both ends. Connect one end of the coiled cable to the modular jack on the motor control box marked "Hand Controller."
3. Connect the other end of the coiled cable to the hand controller modular jack (**Figure 14**).

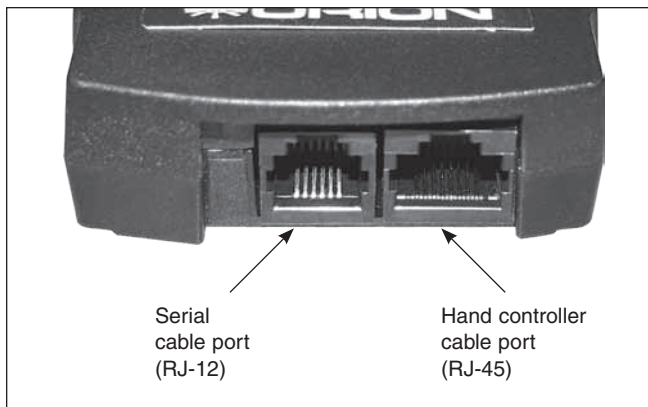

Figure 14. The GoTo hand controller ports

Your SkyView Pro GoTo system is now installed and should resemble the image on the manual cover. You can now proceed to power the system and utilize the many functions of the GoTo hand controller.

3. The SynScan GoTo Hand Controller

Once aligned, the GoTo hand controller and dual-axis GoTo motors and encoders allow you to automatically point your

SkyView Pro mounted telescope at a specific object, or tour the skies with pushbutton simplicity. The user-friendly menu allows automatic slewing to over 42,000 objects. Even inexperienced astronomers will find themselves quickly mastering the variety of features the GoTo hand controller offers in just a few observing sessions.

For more information about the features and functionality of the SynScan GoTo Hand Controller, refer to the separate manual for the controller.

Powering the SkyView Pro GoTo System

The SkyView Pro GoTo system should be powered by a 12V (11V-15V) DC power supply (tip positive) capable of producing continuous current of a minimum 2 amps. We recommend using a portable rechargeable battery, like the Dynamo Pro available from Orion, or an AC-to-12V DC power adapter with 2-amp current rating.

If you are using a portable battery like the Orion Dynamo, use the 12V DC power cable supplied with your mount (male cigarette lighter plug on one end, standard 12V DC power plug on other end) to connect the battery to the 12V DC power jack on the motor control box. Make sure the Dynamo's power switch is in the "on" position after connecting. Then, to turn the GoTo system on, simply press the switch on the motor control box so it is in the "on" position.

One-Year Limited Warranty

This Orion product is warranted against defects in materials or workmanship for a period of one year from the date of purchase. This warranty is for the benefit of the original retail purchaser only. During this warranty period Orion Telescopes & Binoculars will repair or replace, at Orion's option, any warranted instrument that proves to be defective, provided it is returned postage paid. Proof of purchase (such as a copy of the original receipt) is required. This warranty is only valid in the country of purchase.

This warranty does not apply if, in Orion's judgment, the instrument has been abused, mishandled, or modified, nor does it apply to normal wear and tear. This warranty gives you specific legal rights. It is not intended to remove or restrict your other legal rights under applicable local consumer law; your state or national statutory consumer rights governing the sale of consumer goods remain fully applicable.

For further warranty information, please visit www.OrionTelescopes.com/warranty.

Orion Telescopes & Binoculars

Corporate Offices: 89 Hangar Way, Watsonville CA 95076 - USA

Customer Support: www.OrionTelescopes.com/contactus

Copyright © 2014 Orion Telescopes & Binoculars

All Rights Reserved. No part of this product instruction or any of its contents may be reproduced, copied, modified or adapted, without the prior written consent of Orion Telescopes & Binoculars.