

Levenhuk MED 40 Microscopes



User Manual

levenhuk
Zoom&Joy

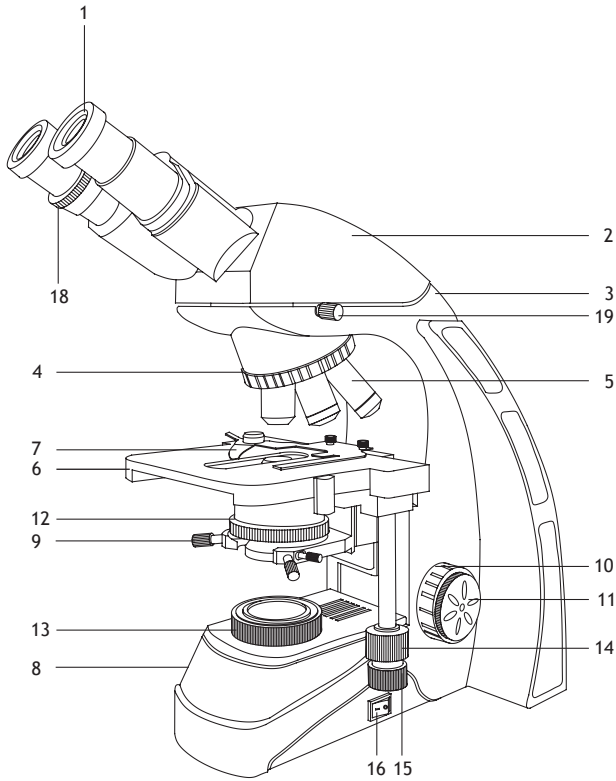

Fig. 1a. Levenhuk MED 40B

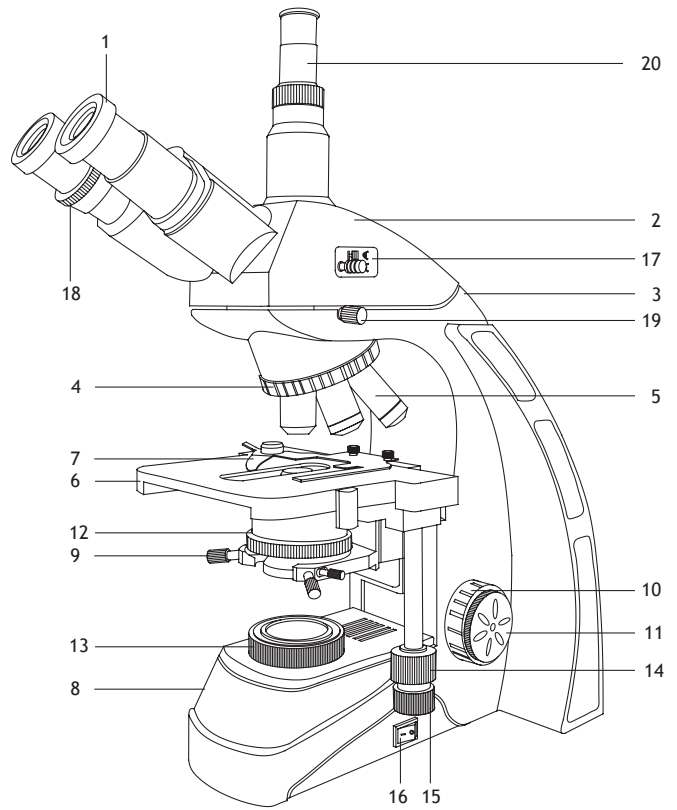

Fig. 1b. Levenhuk MED 40T, D40T, D40T LCD

1 Eyepiece	11 Fine focusing knob
2 Binocular/trinocular eyepiece head	12 Condenser with filter holder
3 Arm	13 Collector
4 Revolving nosepiece	14 Stage moving knob (right/left)
5 Objective	15 Stage moving knob (back/forth)
6 Stage	16 Illumination on/off button
7 Mechanical scale	17 Beam splitter (trinocular models only)
8 Brightness adjustment knob (not shown)	18 Diopter adjustment ring
9 Aperture diaphragm adjustment screws	19 Binocular/trinocular head locking screw
10 Coarse focusing knob	20 Third eyepiece tube (trinocular models only)

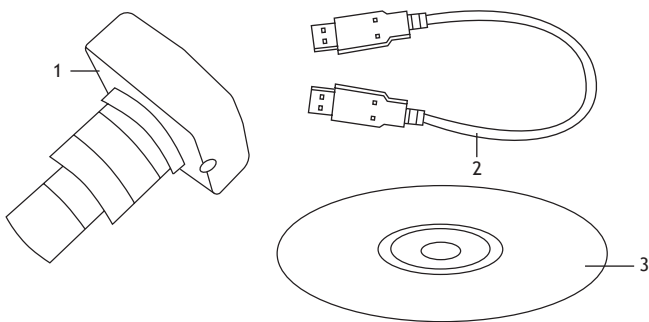

Fig. 2a. Levenhuk MED 40B

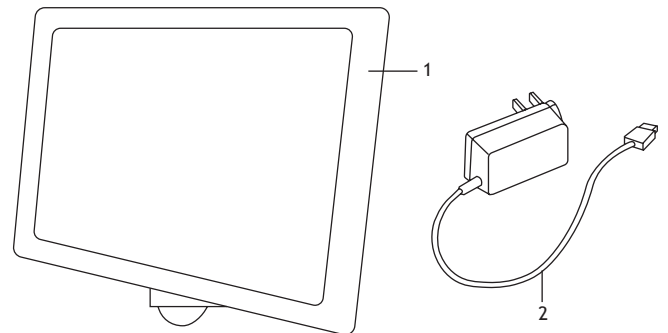

Fig. 2b. Levenhuk MED 40T, D40T, D40T LCD

1 Digital camera	1 Digital camera with LCD screen
2 USB cable	2 AC adapter
3 Installation CD	

General Information

Read the user manual carefully before you start working with a microscope. Levenhuk MED Series biological microscopes are safe for health, life and property of the consumer and the environment when properly used, and meets the requirements of international standards. These microscopes are designed for observing transparent objects in the transmitted light using the bright field method. They perform well in clinical research and tests; teaching demonstrations; bacterioscopy and cytology in medical and health establishments, laboratories, universities; and may be used for scientific research in agriculture and microbiology.

Microscope assembly

- Unpack the microscope carefully and place it on a flat surface.
- Remove the plastic bags and dustproof cover of the eyepiece head.
- Install the binocular or trinocular head and tighten the locking screw.
- Inspect all the items included in the kit and define their purpose.
- Connect the power cord to the microscope and plug it in.

Use

Please refer to the fig. 1a (binocular model) and fig. 1b (trinocular model).

- Turn on the power and the illumination will turn on. Set the brightness at approximately 70%. Place the specimen on the stage. Make sure the clips hold the specimen firmly in place.
- Iris diaphragm should be adjusted in accordance with numerical aperture of a lens. The best practice is to make the iris diaphragm slightly smaller than the aperture of the selected lens. Open or close the iris diaphragm using the adjustment screws. If the adjustment screw is turned to the right, the iris diaphragm is fully open. Note: the diaphragm is not intended for adjusting the brightness of the illumination. To adjust the brightness, use the brightness adjustment knob.
- Slide the filter holder, place the filter in it and then return the holder to its initial position.
- To change the objective magnification, turn the revolving nosepiece until it clicks.
- Make sure that the lens does not touch the sample when adjusting the focus: rotate the coarse focus knob until the specimen is about 3.175mm (1/8") away from the lens.
- Looking into the eyepiece, slowly turn the coarse focusing knob until you can see the image of the observed specimen. Turn the fine focusing knob to make the image clear. The fine focusing mechanism allows you to focus on the observed specimen while using high magnifications.
- When you use an oil immersion objective, the space between the specimen and the lens should be filled with immersion oil. Raise the condenser to the upper position and put a drop of oil on the lens and on the cover glass of the specimen. Move the revolving nosepiece back and forth to get rid of air bubbles in the oil. Then, fix the objective lens in its working position. Make sure that oil fills the entire space between the objective lens and the specimen. After use, wipe the lens dry.
- To adjust the position of the mechanical scale, turn the coarse focusing knob in a clockwise direction if you want to fix the position of the mechanical scale, or in a counterclockwise direction if you want to loosen it.
- To place the specimen in the field of view, move the stage horizontally back and forth or left and right using the stage moving knobs.
- Look through the right eyepiece with your right eye and adjust the image sharpness with the coarse and fine focusing knobs. Then, look through the left eyepiece with your left eye and rotate the diopter adjustment ring to equalize the difference between your left and right eyes vision. Remember the setting for future use. Adjust the distance between the eyepiece tubes of the binocular head so that the image merges into a single circle.
- Trinocular models: you can install the digital camera to the third eyepiece tube. Use the beam splitter to send the light to the eyepieces or to the camera.

Fuse replacement

Unplug the microscope from a power source. Open the fuse holder located on the back of the microscope body with a flat head screwdriver. Remove the old fuse and install a new one. Only use the appropriate types of fuses. Close the fuse holder.

Digital camera

Levenhuk MED D40T comes with a digital camera (fig. 2a), Levenhuk MED D40T LCD comes with a digital camera with an LCD screen (fig. 2b). A digital camera is installed to the third eyepiece tube and enables observing specimens on the screen in exquisite detail and true color, taking photos and videos, and saving the images for future reference.

Specifications

Product ID	74004	74005	74006	74007
Model	MED 40B	MED 40T	MED D40T	MED D40T LCD
Type	biological/optical		biological/optical, digital	
Research method	bright field		bright field	
Magnification	40–1000x		40–1000x	
Interpupillary distance	48–75mm		48–75mm	
Eyepiece head	binocular, 360° rotatable, inclined at 30°	trinocular, 360° rotatable, inclined at 30°	trinocular, 360° rotatable, inclined at 30°	
Optics material	optical glass with an anti-fungal coating		optical glass with an anti-fungal coating	
Eyepiece tube diameter	30mm		30mm	
Third vertical eyepiece tube	–	23.2mm	23.2mm	
Eyepieces	WF10x/22mm (2pcs)		WF10x/22mm (2pcs)	
Eyepiece diopter adjustment	±5D		±5D	
Objectives	Infinity Plan: 4x, 10x, 40xs, 60xs, 100xs (oil)		Infinity Plan: 4x, 10x, 40xs, 60xs, 100xs (oil)	
Revolving nosepiece	5 objectives		5 objectives	
Stage moving range	75/50mm		75/50mm	
Stage	double layer mechanical, 180x150mm, with a mechanical scale		double layer mechanical, 180x150mm, with a mechanical scale	
Focus system	coaxial, coarse (0.5mm) and fine (0.002mm), with rack and pinion mechanism		coaxial, coarse (0.5mm) and fine (0.002mm), with rack and pinion mechanism	
Condenser	Abbe N.A. 1.25 iris diaphragm and filter holder		Abbe N.A. 1.25 iris diaphragm and filter holder	
Body	metal		metal	
Illumination	lower (5W LED) with brightness adjustment		lower (5W LED) with brightness adjustment	
Collector	Köhler illumination		Köhler illumination	
Filters	blue, green, yellow		blue, green, yellow	
Vial of immersion oil	+		+	
Fuse	2pcs		2pcs	
Power supply	100–240V, via AC adapter		100–240V, via AC adapter	
Digital camera	–		16Mpx	5Mpx with LCD screen
Camera connector	–		+	+
Camera power supply	–		DC 5V, via USB 2.0 cable	DC 12V/2A, via AC adapter
Optional accessories (sold separately)	<i>infinity plan objective: 20xs</i>			
	<i>eyepieces (D 30mm): 5x, 12.5x, 16x, 20x</i>			
	<i>dark field condenser</i>			
	<i>standard contrast device</i>			
	<i>plain polarization device</i>			
		<i>digital camera</i>		

Levenhuk reserves the right to modify or discontinue any product without prior notice.



Caution! Please remember that mains voltage in most European countries is 220–240V. If you want to use your device in a country with a different mains voltage standard, remember that use of a converter is absolutely necessary. The microscope must be grounded. Make sure that the main voltage matches the voltage indicated on the microscope body.

Care and maintenance

- **Never, under any circumstances, look directly at the Sun, another bright source of light or at a laser through this device, as this may cause PERMANENT RETINAL DAMAGE and may lead to BLINDNESS.**
- Take necessary precautions when using the device with children or others who have not read or who do not fully understand these instructions.
- After unpacking your microscope and before using it for the first time check for integrity and durability of every component and connection.
- Do not try to disassemble the device on your own for any reason. For repairs and cleaning of any kind, please contact your local specialized service center.
- Protect the device from sudden impact and excessive mechanical force. Do not apply excessive pressure when adjusting focus. Do not overtighten the locking screws.
- Do not touch the optical surfaces with your fingers. To clean the device exterior, use only special cleaning wipes and special optics cleaning tools from Levenhuk. Do not use any corrosive or acetone-based fluids to clean the optics.
- Abrasive particles, such as sand, should not be wiped off lenses, but instead blown off or brushed away with a soft brush.
- Do not use the device for lengthy periods of time, or leave it unattended in direct sunlight. Keep the device away from water and high humidity.
- Be careful during your observations, always replace the dust cover after you are finished with observations to protect the device from dust and stains.
- If you are not using your microscope for extended periods of time, store the objective lenses and eyepieces separately from the microscope.
- Store the device in a dry, cool place away from hazardous acids and other chemicals, away from heaters, open fire and other sources of high temperatures.
- When using the microscope, try not to use it near flammable materials or substances (benzene, paper, cardboard, plastic, etc.), as the base may heat up during use, and might become a fire hazard.
- Always unplug the microscope from a power source before opening the base or changing the illumination lamp. Regardless of the lamp type (halogen or incandescent), give it some time to cool down before trying to change it, and always change it to a lamp of the same type.
- Always use the power supply with the proper voltage, i.e. indicated in the specifications of your new microscope. Plugging the instrument into a different power outlet may damage the electric circuitry of the microscope, burn out the lamp, or even cause a short circuit.
- **Seek medical advice immediately if a small part or a battery is swallowed.**

Levenhuk International Lifetime Warranty

All Levenhuk telescopes, microscopes, binoculars and other optical products, except for accessories, carry a **lifetime warranty** against defects in materials and workmanship. Lifetime warranty is a guarantee on the lifetime of the product on the market. All Levenhuk accessories are warranted to be free of defects in materials and workmanship for **six months** from date of retail purchase. Levenhuk will repair or replace such product or part thereof which, upon inspection by Levenhuk, is found to be defective in materials or workmanship. As a condition to the obligation of Levenhuk to repair or replace such product, the product must be returned to Levenhuk together with proof of purchase satisfactory to Levenhuk. This warranty does not cover consumable parts, such as bulbs (electrical, LED, halogen, energy-saving and other types of lamps), batteries (rechargeable and non-rechargeable), electrical consumables etc. For further details, please visit our web site: www.levenhuk.com/warranty

If warranty problems arise, or if you need assistance in using your product, contact the local Levenhuk branch.